

Acterna ANT-5 SDH Access Tester up to STM-16

The access network explosion

The modern communications market is challenging network operators in new ways. Because growth from traditional voice services has declined, operators must find new ways to carry more data traffic in order to maintain their revenue stream. However, bandwidth bottlenecks in the access and metro networks have prevented many new high-speed, high-bandwidth services from being efficiently deployed.

Field technicians, who are tasked with installing and maintaining these networks, must learn how to test a wide variety of technologies while they strive to reach new levels of productivity. To perform these tasks, technicians require an increased number of pieces of equipment and additional training to operate each device effectively.

Additionally, operators must be able to manage the conflicting demands of technicians, who need the proper equipment and training to do their jobs, and executives, who are keeping close control on capital expenses and operating costs.

The ANT-5 rises to the challenge

Acterna effectively meets the challenges faced by network operators with the Acterna ANT-5 SDH Access Tester. Designed for field operations, the small, rugged, battery-operated ANT-5 streamlines installation and maintenance testing. Its advanced features and automated functions enable technicians to perform tests quickly and effectively. And, with SDH, PDH, SONET, and ATM combined into a single compact unit, capital investment and training expenses are reduced, minimizing business costs.

Highlights

- Smallest and lightest test solution (only 2.2 kg) for interfaces from 1.544 Mbps up to 2.5 Gbps
- Optical testing at dual wavelengths from STM-1/OC-3 up to STM-16/OC-48
- Electrical testing at DS1, E1, E3, DS3, E4, STM-0, and STM-1/OC-3
- Full analysis of concatenated mappings with SDH/SONET signals
- In-depth PDH analysis with Sa bit generation and flexible mux/demux test configuration
- Optical power measurements for verification of physical layer integrity
- ATM functionality for service verification of ATM, 3G, and UMTS networks (provided via T-carrier, PDH, SDH, or SONET)
- In-line Monitor and Intrusive Thru Modes for traffic analysis and network testing
- ECL/NRZ port enables non-intrusive direct monitoring of optical networks

The portable solution

The ANT-5's compact, robust design is ideal for field and central office applications. The convenient, built-in stand and comfortable carry strap enable hands-free testing in any location. And, its extended battery life allows for testing even when AC power is not on hand.

Optional carrying cases protect the ANT-5 when technicians travel between sites and provide a safe and convenient place for storing cables and accessories.

Simplest handheld to learn and use

Access technicians need a tester that can simplify their key tasks without extensive training. With its large color screen, graphical user interface (GUI), and ergonomic keypad, the ANT-5 is the simplest handheld to learn and use on the market today. Other features include:

- Labelled LEDs that show current and historical alarms
- OK results summary and pass/fail results screen displays
- Auto-save of test results
- Fast store and recall of key network configurations
- Auto-configuration detects actual signal structure
- Automatic testing

Easiest to use

Technicians prefer instruments that are the easiest to use, so that they can concentrate their efforts on measurement tasks rather than on the complex operation of the instrument itself.

The ANT-5 is the most complete instrument, with all of the necessary interfaces already built-in, including T1 Bantam, E1 balanced, and E1 unbalanced up to optical interfaces with STM-16/OC-48. It covers T-carrier, PDH, SDH, and SONET technology, all in one instrument.

The ANT-5's world-class ease-of-use is based on a clearly structured operation concept: SETUP – RESULTS – ACTIONS.

The ANT-5 offers three operation modes to cover all necessary field applications, including intrusive, non-intrusive, and monitoring modes. An important feature is the ECL/NRZ port for monitoring optical circuits at electrical monitor points provided by network elements (STM-1/-4/-16).

The navigation key allows for simple operation, and the keyboard supports the easy input of comments, file names, etc.

The internal memory can hold hundreds of files. For result analysis and report generation, the ANT-5 allows for the easy transfer of files to the instrument's Compact Flash Memory Card (CF card). In addition, the Microsoft® Windows®-based Off-line Viewer provides simple results analysis.

For report generation, the Off-line Viewer print functions can be used, supporting any of your desktop printers in your Windows environment.

Application selection

The ANT-5 application menu opens direct access to the following applications:

- Performance Analysis (according to ITU-T, ANSI)
- Repetitive BERT (radio link application)
- Automatic Protection Switching (APS)
- Service Disruption Measurements
- OH Capture
- Round Trip Delay Measurements (RTD)

The corresponding results are directly accessible in the results page structure.

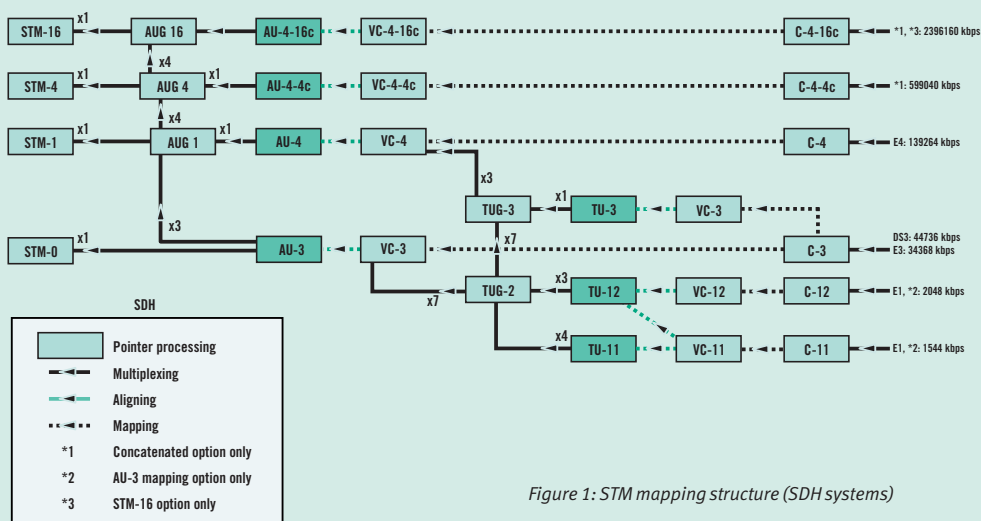

Figure 1: STM mapping structure (SDH systems)

The access technicians' tool of choice

The ANT-5 provides all of the transmission test functions required in today's access networks:

- Optical power measurement
- Bit error rate testing
- G.821, G.826, G.828, G.829, ANSI, M.2100, and M.2101 analysis
- Received signal offset measurement
- Transmit signal offset and generation
- Tabular and graphical event recording

Extensive SDH/SONET features

The ANT-5 is loaded with SDH and SONET test features covering all installation and maintenance tasks up to 2.5 Gbps:

- STM-0e, STM-1e/STS-3 interface
- STM-1/OC-3 to STM-16/OC-48 optical ports at dual wavelengths (1310/1550 nm)
- Auto-configuration
- Anomaly generation and analysis
- Defect generation and analysis
- SOH/POH generation and analysis (HEX or clear text format)

- Pointer generation and analysis
- Path trace generation and analysis
- Tandem connection monitoring (TCM) generation and analysis
- APS/service disruption measurements
- RTD measurements
- Automatic tributary scanning
- K-byte capture

Full PDH support

From 1.5 Mbps to 140 Mbps, including nx64 Kbps, the ANT-5 can test all PDH tributaries and legacy PDH hierarchy transmission systems using high-level functions that include E1 Sa bit generation and display.

T-carrier support

The ANT-5 is also equipped with a standard T1 Bantam interface and supports DS1 and DS3 interfaces and structures.

In addition, the multiplexer/demultiplexer (mux/demux) option now supports M13 framing (DS1/DS3) and allows for 64 K channel analysis.

ATM service verification

UMTS network rollout and ADSL growth is increasing the use of ATM in the access network. The ANT-5 enables the installation and maintenance of ATM carried over PDH, SDH, and SONET networks that include:

- DS1, STS-1 SPE, DS3
- E1, E3 (G.832), E4
- VC-4/STS-3c SPE
- VC-4-4c/STS-12c SPE

PVC cells can be generated over UNI and NNI with CBR and VBR traffic load profiles up to STM-4c rates.

Service quality can be checked using BER or O.191 measurements. Link and channel performance can be monitored while traffic statistics are recorded.

Channel Explorer scans automatically for active VCI/VPI and displays the result in tabular form.

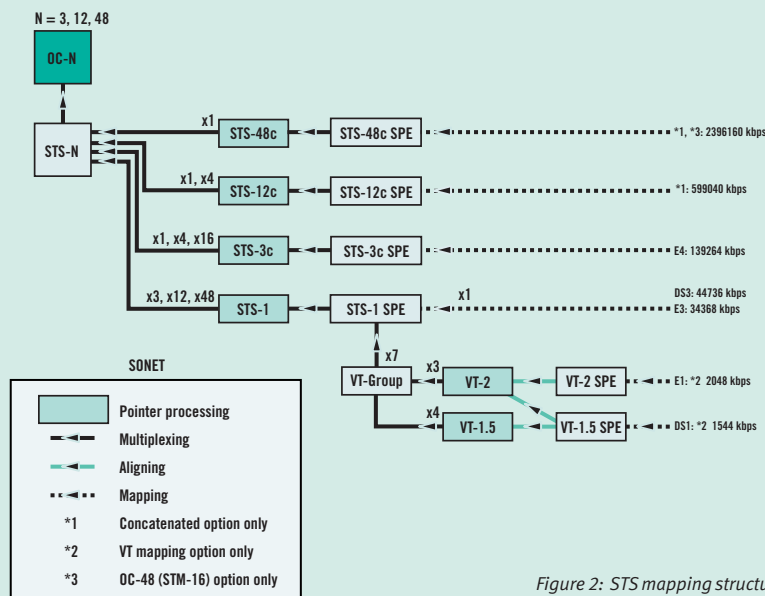

Figure 2: STS mapping structure (SONET systems)

Simple test and results management

Due to its built-in Ethernet port, CF card port, and printer port, the ANT-5 can integrate more effectively and simply with day-to-day operations.

- Export standard test setups to other ANT-5s or PCs via the CF card
- Exchange results over LANs using Windows-based PCs
- Print test reports directly via the serial interface or from a PC using the Off-line Viewer software

Result evaluation (Off-line Viewer)

Results (in ANT-5 format) can be loaded, analyzed, and printed by any Windows-based PC using the ANT-5 Off-line Viewer software.

Off-line Viewer enables the generation of specific setups with easy downloading to the instrument. The user interface can be displayed in the following languages: English, German, French, Italian, Spanish, Portuguese, and Chinese. This Windows-based software, included with each instrument, can also be used for training purposes, providing an excellent product simulation.

Remote GUI

Remote operation is achieved by establishing a suitable communications link over an Ethernet LAN. Once the link has been successfully set up, the PC/laptop can communicate with the ANT-5 using the supplied version of the ANT-5 GUI faceplate.

Advanced remote testing capability

The ANT-5 also provides an advanced remote testing capability over Ethernet. As a result, technicians can poll instruments remotely from their offices, simplifying long-term commissioning and maintenance tests and dramatically reducing travel time and costs. Test results can be saved to any network hard disk or printed from any network printer for convenient analysis.

Flexible, cost-effective platform

The ANT-5's flexible design enables it to be adapted quickly to operators' changing requirements. In addition, its field upgradeable capability, provided by the Compact Flash port, enables technicians in the field to install software in minutes.

Hardware upgrades can be purchased to add optical bandwidths or wavelengths. This protects the initial investment and reduces additional training expenses while allowing operators to match capital expenditures to network rollout plans.

The Acterna ANT-5 is an industry-leading access tester that sets new standards for portability, ease of use, and adaptability. It is the ideal device for field technicians who need to test a range of SDH, PDH, SONET, and ATM digital links both onsite and from a remote location. As a result, the ANT-5 provides a significant advantage for companies wishing to optimize quality of service using a cost-effective, industry-proven solution.



Figure 3: View of the right panel showing the CF card, RS-232, T1 Bantam, and ECL/NRZ ports



Figure 4: Off-line Viewer and remote operation (GUI)

Technical Specifications

Electrical Interfaces

6.703 transmitters

BNC 75 Ω unbalanced outputs

Bit rates and line codes	
– 2048, 34368 Kbps	HDB3
– 44736 Kbps ⁽¹⁾	B3ZS
– 51840 Kbps	B3ZS
– 139264, 155520 Kbps	CMI

RJ48 120 Ω balanced output

Bit rate and line codes	
– 2048 Kbps	HDB3

Electrical Interfaces

BNC 75 Ω unbalanced inputs

Bit rates and line codes	
– 2048, 34368 Kbps	HDB3
– 44736 Kbps ⁽¹⁾	B3ZS
– 51840 Kbps	B3ZS
– 139264, 155520 Kbps	CMI

RJ48 120 Ω balanced input

Bit rate and line codes	
– 2048 Kbps	HDB3

Clock Recovery

- Pulling range as G.703

Selectable input gain

– 155520 Kbps	20 dB
– 2048, 34368 Kbps	26 dB
– 44736, 139264 Kbps	26 dB

T1 Interface

Connectors	Bantam
Input impedance	100 Ω
Bit rate	1544 Kbps
Line code	AMI, B8ZS

E1 Hi-Z Input

A high input impedance setting for the E1 75 Ω, E1 120 Ω, and T1 100 Ω ports enables these signals to be monitored without a PMP.

⁽¹⁾ANSI T1.101 compliant

Optical Interface (Options)

6.957 optical transmitter and receiver (options)

– Class 1 laser product

Connectors

FC-PC connectors

Transmitter wavelengths

Single (1310 nm), Dual (1310 nm and 1550 nm)

Line bit rates

155.52 Mbps, 622.08 Mbps, 2488.32 Mbps

Line code

scrambled NRZ

Optical Transmitter Specifications

Optical option	Line rate	Wavelength	Tx output power @ 1310 nm	Tx output power @ 1550 nm
BN4565/00.01	STM1	1310SR	-8 dBm to -15 dBm	
BN4565/00.03	STM1	1310SR/1550LR	-8 dBm to -15 dBm	+2 dBm to -4 dBm
BN4565/91.13	STM1/4	1310SR	-8 dBm to -15 dBm	
BN4565/00.14	STM1/4	1310SR/1550LR	-8 dBm to -15 dBm	+2 dBm to -4 dBm
BN4565/91.15	STM1/4	1310LR/1550LR	+2 dBm to -4 dBm	+2 dBm to -4 dBm
BN4565/91.16	STM1/4/16	1310LR/1550LR	+3 dBm to -3 dBm	+3 dBm to -3 dBm

Optical Receiver Specifications

Optical option	Line rate	Wavelength	Rx dynamic range @ 1100 to 1600 nm	Rx optical overload
BN4565/00.01	STM1	1310SR	-8 dBm to -28 dBm	N/A
BN4565/00.03	STM1	1310SR/1550LR	-8 dBm to -28 dBm	N/A
BN4565/91.13	STM1/4	1310SR	-8 dBm to -28 dBm	N/A
BN4565/00.14	STM1/4	1310SR/1550LR	-8 dBm to -28 dBm	N/A
BN4565/91.15	STM1/4	1310LR/1550LR	-8 dBm to -28 dBm	N/A
BN4565/91.16	STM1/4/16	1310LR/1550LR	-8 dBm to -28 dBm	-6 dBm

Optical Power Measurement

Measurement of the received optical signal level

Resolution 1 dB

Electrical Interfaces

For connecting the ANT-5 to STM-1/OC-3, STM-4/OC-12, and STM-16/OC-48 monitor points

Line code scrambled NRZ

Input voltage (peak-to-peak) 0.2 to 1 V

Coaxial input

Connector/impedance SMA/50 Ω

Transmit Clock Synchronization

Internal stability ±3.6 ppm

Tx bit rate offset ±100 ppm

Increment 0.1 ppm

External Clock (SDH Transmitter)

Connector BNC 75 Ω (120 Ω via external adapter)

Reference clock 1544, 2048 kHz

Reference signal 1544, 2048 Kbps (HDB3)

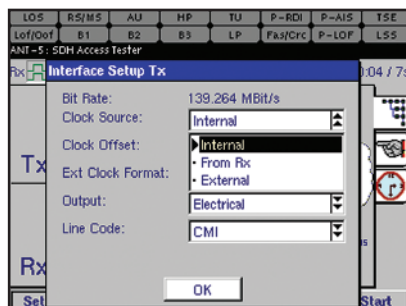

Figure 5: Menu for the external clock



Figure 6: View of the top panel showing the electrical and optical interfaces

Technical Specifications – SDH

SDH

Operating Modes

- Terminated Mode
- In-line Monitor Mode
- Intrusive Thru Mode

SDH Output Signals

STM-0 signal consists of one VC-n container with

- Framed or unframed PDH test pattern
- Test pattern without stuffing bits (bulk signal to 0.181)

STM-1 signal consists of one VC-n container with

- Framed or unframed PDH test pattern
- Test pattern without stuffing bits (bulk signal to 0.181)

Content of nonselected containers

- STM-1 PRBS 2¹¹-1 (framed/unframed as per selected container)

STM-4 signal consists of one VC-n container with

- Framed or unframed PDH test pattern
- Test pattern without stuffing bits (bulk signal to 0.181)
- Three VC-4 containers each filled with a fixed pattern of 11100110

STM-16 signal consists of VC-n containers with

- Framed or unframed PDH test pattern
- Test pattern without stuffing bits (bulk signal to 0.181)

SDH Anomaly and Defect Insertion

Defect generation

Static ON/OFF

Anomaly generation

Single or at a continuous error ratio of 1x10⁻ⁿ (where the range of n is as indicated below)

Payload

Bit errors (TSEs) n = 2-9

Anomalies

B1, B3	n = 4-9
MS-REI	n = 3-10
LP-REI, LP-BIP (except C4)	n = 3-10
B2	n = 3-9
HP-REI	n = 4-10

SDH Anomaly/Defect Burst Generation

Anomalies (injected in n consecutive frames every m frames or seconds)

B1, B2, MS-REI, B3, HP-REI, LP-BIP, LP-REI

Defects

LOS, LOF, RS-TIM, MS-AIS, MS-RDI, AU-LOP, AU-AIS, HP-UNEQ, HP-RDI, HP-TIM, HP-PLM, TU-LOP, TU-AIS, TU-LOM, LP-UNEQ, LP-RDI, LP-TIM, LP-PLM, LP-RFI

SDH Error and Alarm Detection

Error types

B1, B2, B3, MS-REI, HP-REI, LP-REI, TSE, LP-BIP, PDH, FAS-45, FAS-34, FAS-2, FAS-1.5, REI-45, CPBIT, EBIT-2, CRC-2, code errors (2 Mbps, 45 Mbps), HP-IEC, LP-IEC, HP-OEI, HP-TC-DIFF, HP-TC-REI

Alarm detection

All alarms are monitored and detected simultaneously.

Alarm types

LOS, OOF, LOF, MS-AIS, MS-RDI, RS-TIM, AU-AIS, AU-LOP, AU-NDF, HP-RDI, HP-UNEQ, HP-TIM, HP-PLM, TU-AIS, TU-LOP, TU-LOM, LP-RDI, LP-PLM, LP-UNEQ, LP-TIM, LSS, LP-RFI, PDH-AIS, PDH-RDI

Mappings (to ITU G.707)

The following mappings are provided as standard with the instrument. (For the structure, see Figure 1.)

- C11 mapping (1.5 Mbps)
- C12 mapping (2 Mbps)
- C3 mapping (34, 45 Mbps)
- C4 mapping (140 Mbps)

Test Patterns

Test patterns may be generated and measured for any of the provided bit rates either directly at the SDH interface or within the STM-16/STM-4/STM-1 substructure.

PRBS: 2¹¹-1, 2²⁰-1, 2²³-1, 2³¹-1, 2¹¹-1 inv, 2¹⁵-1 inv, 2²⁰-1 inv, 2²³-1 inv, 2³¹-1 inv, QRSS20

User programmable word 16 bits

Overhead Evaluation and Generation

SOH and POH evaluation

Display of complete SOH and POH in hex, binary, and ASCII formats.

Text decode of S and C bytes for the trace identifier.

J0 display of 16 byte ASCII sequence.

J1 and J2 display of 16 or 64 byte ASCII sequence.

SOH and POH generation

The content of all bytes, with the exception of A1/A2, B1/B2/B3, and H1 to H4, is programmable with any byte.

- Selectable synchronization messages (S byte)
- Selectable signal labels (C byte)
- Trace identifier
- J0 programmable 1 byte hexadecimal or 16 byte ASCII sequence with CRC
- J1 and J2 programmable 16 byte ASCII sequence with CRC or 64 byte ASCII sequence

Pointer Analysis and Generation in AU/TU

Pointer analysis

Current pointer values displayed

Displays counts of:

- Pointer increments and decrements, sum and difference
- New data flags (NDFs)

– Average deviation (in ppm) of AU and TU

User selectable recording of pointer events into the event log.

Pointer generation

Generation of pointers by:

- Single pointer
- INC or DEC or INC/DEC

Frame rate: 100 to 8000

Receive K-Byte Capture

Captures K1 and K2 bytes

Capture trigger criteria: user selectable

Tandem Connection Monitoring (TCM)

Monitoring

Analysis of N1 and N2 bytes

Monitoring/display of:

TC-IEC, TC-AIS, TC-REI, TC-OEI, TC-UNEQ, LTC, TC-AIS, TC-RDI, TC-ODI, TC-REI

Online display of TCM access point identifier

TCM error measurement

Incoming B3/computed BIP comparison

Generation

Generation of N1 and N2 bytes

To create:

TC-IEC, TC-AIS, TC-REI, TC-RDI, TC-OEI, TC-ODI, TC-UNEQ

Signal Frequency Measurement

Receive signal frequency is displayed and deviation from nominal shown in ppm.

Resolution 0.1 ppm

Technical Specifications – PDH

PDH
Operating Modes
– Terminated Mode
– In-line Monitor Mode
– Intrusive Thru Mode (E1 only)
PDH Output Signals
Signal structures
– Unframed test pattern
– Framed test pattern (to ITU-T 0.150)
Frame types
– 1544 Kbps unframed/framed (SF, ESF)
– 2048 Kbps unframed/framed G.704 CAS PCM31, PCM3CRC, PCM30, PCM30CRC
– 34368 Kbps unframed/framed G.751, G.832
– 44736 Kbps unframed/framed C-parity, M13
– 139264 Kbps unframed/framed G.751

PDH Anomaly and Defect Insertion	
Payload	Bit errors (TSEs) n=2-9
Defect generation	Static ON/OFF
Defect types	AIS, LOF, RDI, LOS, Yellow (1.5, 45 Mbps), Idle (45 Mbps only), DS1 code error inject, DS3 error code/ PVP analysis
Anomaly generation	Single or at a continuous error ratio of 1×10^{-n} (where the range of n is as indicated below)
Anomaly types	FAS n = 3-10
	EBIT (framed 2 Mbps only) n = 3-10
	CODE (framed 2 Mbps only) n = 3-8
	CRC (framed 2 Mbps ESF only) n = 3-9
	CRC (framed 1.5 Mbps ESF only) n = 3-9
	P-BIT (framed 45 Mbps only) n = 4-8

PDH Error and Alarm Detection
Error types
MS-REI, HP-REI, LP-REI, TSE, LP-BIP, PDH, FAS-45, FAS-34, FAS-2, FAS-1.5, REI-45, CPBIT, EBIT-2, CRC-2, code errors (2 Mbps, 45 Mbps), HP-IEC, LP-IEC, HP-OEI, HP-TC-DIFF, HP-TC-REI
Alarm detection
All alarms are monitored and detected simultaneously.
Alarm types
LOS, OOF, LOF, MS-AIS, MS-RDI, RS-TIM, AU-AIS, AU-LOP, AU-NDF, HP-RDI, HP-UNEQ, HP-TIM, HP-PLM, TU-AIS, TU-LOP, TU-LOM, LP-RDI, LP-PLM, LP-UNEQ, LP-TIM, LSS, LP-RFI, PDH-AIS, PDH-RDI, Yellow (1.5, 45 Mbps only), Idle (45 Mbps only)
Test patterns
Test patterns may be generated and measured for any of the provided bit rates either directly at the PDH interface or within the STM-16/STM-4/STM-1 substructure.
PRBS: $2^{11}-1$, $2^{15}-1$, $2^{20}-1$, $2^{23}-1$, $2^{31}-1$, $2^{11}-1$ inv, $2^{15}-1$ inv, $2^{20}-1$ inv, $2^{23}-1$ inv, $2^{31}-1$ inv, QRSS20
User programmable word 16 bits
Signal Frequency Measurement
Receive signal frequency is displayed and deviation from nominal shown in ppm.
Resolution 0.1 ppm

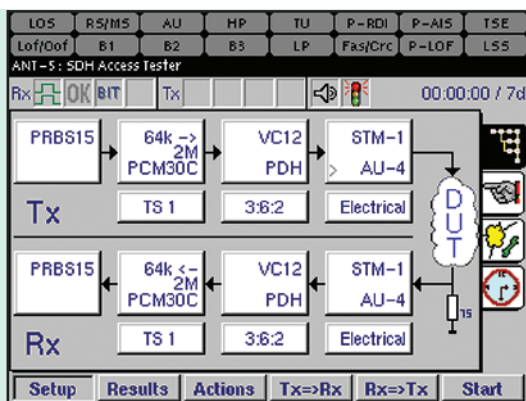

Figure 7: SDH signal structure page

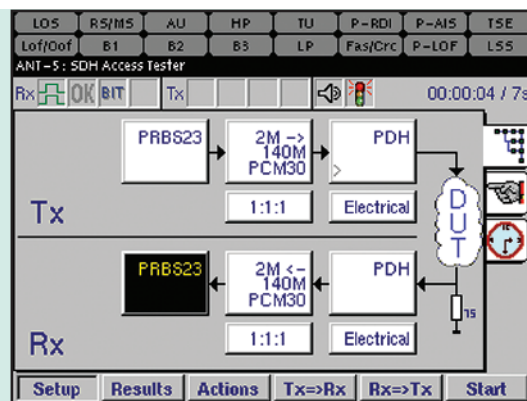

Figure 8: PDH signal structure page

Technical Specifications – ATM (Option)

ATM (Option)

For testing of ATM services carried over PDH, SDH, and SONET

- Tests ATM over DS1, E1, E3, DS3, E4, VC-4/OC-12 and VC-4c/OC-12c, STS-1 SPE

Operating Modes

- Terminated Mode
- In-line Monitor Mode
- Intrusive Thru Mode (E1 only)

ATM Interfaces

Signal structures for all bit rates

- Unframed test pattern
- Framed test pattern

Frame types

- 1544 Kbps unframed/framed (SF, ESF)
- 2048 Kbps unframed/framed G.704 CAS, 30/31 channels with/without CRC
- 34368 Kbps unframed/framed G.751, G.832
- 44736 Kbps unframed/framed C-parity, M13
- 139264 Kbps unframed/framed G.751

ATM Layer Traffic Generation

Traffic generation

1 foreground, 1 background channel

Interface UNI/NNI according to 1.361

Payload scrambling Enable/Disable

Rate adaption by stuffing Idle/Unassigned

Traffic profile

Traffic selection Cell(s), %

Type GBR, VBR (specifying PCR, SCR)

ATM test cells

Full cell header editing including:

VPI 0 to 255
 VCI 0 to 65535
 GFC 0 to 15
 CI ON/OFF
 CLP 0/1

Payload type foreground channel:

- AAL-0 filled with test pattern
- 0.191 test cell format (1995, 1997)

ATM Layer Traffic Analysis

ATM cell analysis

Analysis of ATM cells according to OAM cell analysis for VC/VP AIS and RDI

Filter function for:

VPI 0 to 255
 VCI 0 to 65535
 CLP 0/1

ATM link and channel statistics

Counts on link parameters:

Total, Load, Idle/Unassigned, CLP = 1, OAM

Counts on ATM channel/path under test (filtered VCI, VPI):

Total, CLP = 1, OAM

0.191 QoS measurements

Reported anomalies:

Cell Loss, Cell Error, Cell Mis-insertion

Reported delay results:

Min CTD, Max CTD, Mean CTD, 2-pt CDVpp

ATM Channel Explorer

Automatic detection of active VCIs/VPIs with the user-defined range.

The results are listed in tabular form.

Test patterns

Test patterns may be generated and measured for any of the provided bit rates either directly at the ATM interface or within the STM-16/STM-4/STM-1 substructure.

PRBS: 2¹¹-1, 2¹⁵-1, 2²⁰-1, 2²³-1, 2³¹-1, 2¹¹-1 inv, 2¹⁵-1 inv, 2²⁰-1 inv, 2²³-1 inv, 2³¹-1 inv

User programmable word 16 bits

ATM Anomaly and Defect Insertion

ATM anomaly generation

Single injection

ATM anomaly types

The following anomalies can be generated:

HUNC, HCOR, Cell Error, Cell Loss

ATM defect generation

Static ON/OFF

ATM defect types

The following defects can be injected:

VC-AIS, VC-RDI, VP-AIS, VP-RDI

ATM Anomaly and Defect Detection

ATM LED indicators

The following status LEDs at the top part of the display will directly reflect the most critical ATM alarms/defects:

ATM VP, ATM VC, LCD, LSS

ATM anomaly detection

The following anomalies will be detected and shown with the results pages (Anomaly Count, Graphs, Event Log):

HUNC, HCOR

ATM defect detection

The following ATM defects will be detected and listed either in tabular form with the defect panel or graphical form with the Graph (defects) page:

LCD, CTM, VC-AIS, VC-RDI, VP-AIS, VP-RDI

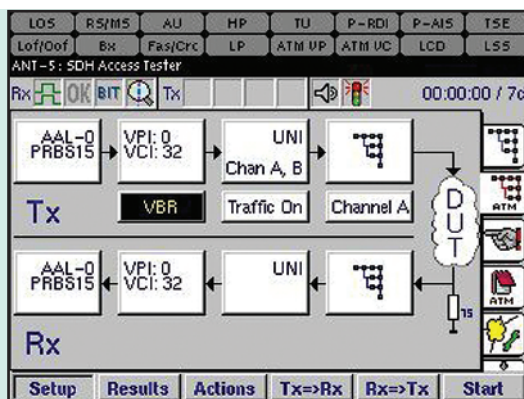

Figure 9: ATM signal structure

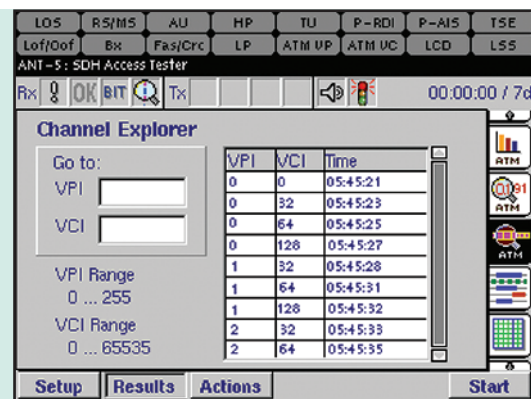

Figure 10: ATM Channel Explorer

Technical Specifications – Measurement Selection

Measurement Selection

The ANT-5 offers direct selection of the following measurement tasks:

- Performance Analysis
- Repetitive BERT
- Automatic Protection Switching (APS)
- OH-Capture (SDH only)
- Delay (RTD)
- Tributary Scan (SDH only)

Performance Analysis

ITU-T Recommendation G.821

ES, EFS, SES, DM, and UAS are evaluated. Pass/fail assessment is based on line length allocation of 1 to 100%. Evaluation for higher bit rates (up to 140 Mbps) is obtained using a multiplex factor as per annex D of G.821. Measurements can be made using the following events: bit errors (TSEs), FAS-2, CRC-4, E bit, code errors (2 Mbps), FAS-34, and FAS-140

ITU-T Recommendation G.826

EB, BBE, ES, EFS, SES, and UAS are evaluated. Pass/fail assessment is based on line length allocation of 1 to 100%. The SES and UAS thresholds can be set by users.

In-service measurement (ISM)

Simultaneous in-service measurement of the near end and far end of a selected path. Measurements can be made using the following events: RSOH B1, MSOH B2, HP B3, FAS-140, FAS-34, FAS-2, CRC, code errors (2 Mbps), and LP-BIP.

Out-of-service measurement (OOS)

Out-of-service measurement using bit errors in the test pattern (for PDH and SDH).

ITU-T Recommendation G.828 Results

ES, EFS, SES, BBE, SEP, and UAS are evaluated. Pass/fail assessment is based on path allocation of 1 to 100%. The SES and UAS thresholds can be set by users.

Hierarchy

RSOH B1, MSOH B2, HP B3, LP-BIP, TSE

ITU-T Recommendation G.829

ES, EFS, SES BBE, and UAS are evaluated. The SES threshold can be set by users.

Hierarchy

RSOH B1, MSOH B2, TSE

ITU-T Recommendation M.2100

ES, EFS, SES, and UAS are evaluated. Pass/fail assessment is based on line length allocation of 1 to 100%. The UAS and BISO (bringing into service objectives) thresholds can be set by users.

PDH systems

Measurements can be made using the following events: TSE, FAS-1.5, FAS-2, FAS-34, FAS-140, CRC, and code errors (2 Mbps)

ITU-T Recommendation M.2101

ES, EFS, SES, BBE, SEP, and UAS are evaluated. Pass/fail assessment is based on line length allocation of 1 to 100%. The UAS and BISO (bringing into service objectives) thresholds can be set by users. ISMs can be performed simultaneously for the near end and far end of a selected path.

Measurements can be made using the following events:

TSE, LP-BIP, HP-B3, MSOH-B2, and RSOH-B1

Repetitive BER Test

- BER evaluation over a user-definable period of 1-99 seconds
- Automatically repeating feature
- Progress bar displays the current test period
- Large character display of BER result

Auto Protection Switching (APS)

Operates on SDH and PDH interfaces (2 M)

Trigger criteria MS-AIS, AU-AIS, TU-AIS, or bit error service disruption*

Pass/fail time limits 10 to 2000 ms
Resolution 1 ms

*Definition of service disruption:

Measurement starts with any of the following events:

TSE, AIS, LOF, or LOS

Measurement stop trigger Last event

Overhead Byte Capture (SDH only)

Byte capturing with number and time frame recognition for linear and ring structures.

Trigger source K1, K2 byte

Trigger criteria Manual, Compare, Compare Not

Delay (RTD)

Resolution ±1 µs

Except for:

E1 PDH ±100 µs

E1 SDH VC-12 ±100 µs

E2 (within PDH E3 or E4) ±10 µs

VC-11/-12 bulk ±10 µs

Measurement range 10 s

VC-12 Tributary Scan (SDH only)

Enables sequential BER testing of C12 channels using configured test pattern. Automatically scans selected VC-12 containers for defects and anomalies.

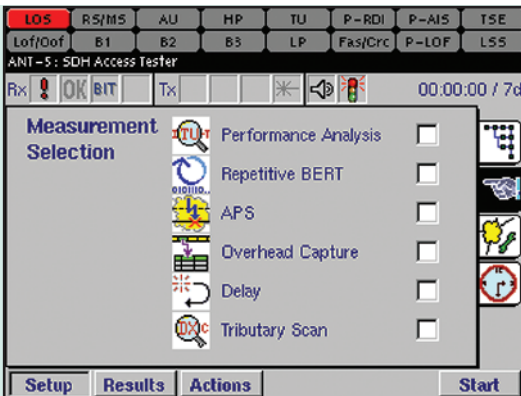

Figure 11: Measurement selection

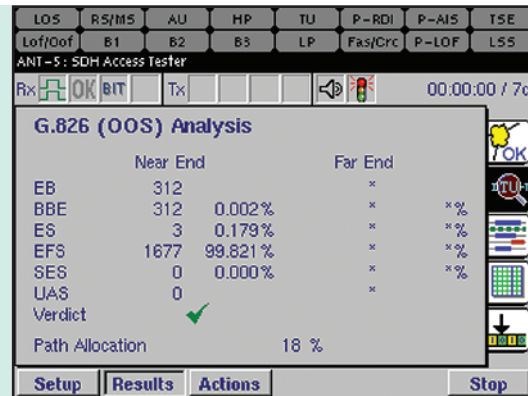

Figure 12: G.826 performance analysis

General Specifications

Display/Language/Timer

Display

Color TFT LCD screen

Resolution 320 x 240 pixels

Languages

The user interface can be displayed in the following languages:

English, German, French, Italian, Spanish, Portuguese, and Chinese

Measurement timer

Variable 1 second to 99 days

Measurement start Manual or delayed start timer

Measurement stop Manual or automatic timer

Display of elapsed time hh:mm:ss

Peripheral Interface

Ethernet communication port

RJ-45 Connector, 10BaseT, TCP/IP

Compact Flash Card

Compact Flash card slot Type I and II

Result/Event Presentation

Alarm notification

Most important anomalies and defects are indicated via LEDs, on-screen graphic icons, and via an audio beeper.

LED event history

On screen soft LEDs and defect panel alarms can be set to display historical events. These are displayed in yellow to easily distinguish them from current alarms that are displayed in red.

OK summary display

Display of large "OK" for error-free circuits for fast and simple installation checks. Upon detection of any anomaly or defect, the "OK" is removed and replaced with a hierarchical list of events, allowing for the easy diagnosis of problems. Display of signal structure with BER or BLER displayed simultaneously.

Defect panel

On-screen hierarchical LED indication of defects.

Anomaly count

Table of all anomalies with a measured count and ratio.

Event log

Tabular display of time stamped events.

Alarm and error resolution 100 ms

Graphical display/histogram

Display of errors and alarms as bar graphs versus time.

Zoom function allows display resolution of seconds, minutes, hours and days.

Results Storage/Transfer/Printing

Results storage

Results can be stored either with the internal memory or on external memory (Compact Flash card)

Internal memory

Memory capacity up to 10,000 entries (approximately seven days at one entry per minute)

Results export

Results can be exported to PC in .CSV format using V.24, Ethernet (requires remote operation option BN4565/00.60), or a Compact Flash card. These results can be processed using standard PC software, such as Microsoft Excel or Word.

Printer interface/remote interface

– Serial V.24/RS-232

– Parallel using adapter cable K1589

– ASCII printing possible

Printing

Setups and measurement results can be printed using printers compatible with DeskJet, ThinkJet, Epson 9, and Epson 24 printer drivers.

Powering

Power outage function

In the event of an AC line power failure during a measurement, the ANT-5 continues to perform measurements using its internal batteries.

Power supply

AC line voltage using series specific adapter

100 to 240 V

AC line frequency 50/60 Hz

Typical operating time on batteries 3 hours

Safety Classification

Safety class to IEC 1010-1 Part 1 (for connection to SELV only)

Pollution environment degree 2

Installation category II (indoor use)

Temperature Range

Ambient temperature

Nominal range of use +5° C to +45° C

Storage/transport range –20° C to +60° C

Weight and dimensions (L x W x H)

Dimensions 275 mm x 197 mm x 76 mm

Weight 2.2 kg

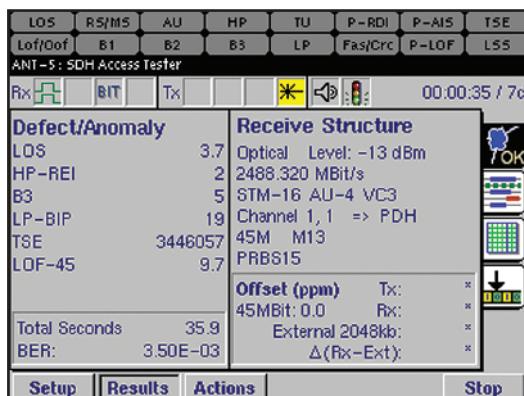

Figure 13: Results page

Options

SDH AU-3/SONET VT Mapping **BN4565/93.53**

The AU-3 mapping function enables testing of DS-1, E1, E3 and DS3 tributaries mapped into the STM-1 signal via VC-3/AU-3.

VC-11/TU-11 1544 Kbps in STM-1 via TU-11, AU-3
 VC-11/TU-12 1544 Kbps in STM-1 via TU-12, AU-3
 VC-12 2048 Kbps in STM-1 via TU-12, AU-3
 VC-3 34368 Kbps in STM-1 via VC-3, AU-3
 44736 Kbps in STM-1 via VC-3, AU-3

The VT mapping function enables testing of DS-1 and E1 tributaries mapped into an STS-1 SPE via VT-1.5 and VT-2 SPEs (requires option BN4565/93.62 SONET STS-1/STS-3c/OC-12c mapping).

ATM

BN4565/93.54

For testing of ATM services carried over PDH, SDH, and SONET.

- Tests ATM over DS1, E1, E3, DS3, E4, VC-4/OC-12 and VC-4c/OC-12c, STS-1 SPE
- Supports ATM traffic selection with time slot 16 in PCM31/PCM31c mode
- CBR and VBR traffic generation
- Full cell header editing
- Cell BER tests
- 0.191 QoS measurements
- ATM link and channel statistics
- OAM cell generation and analysis for VC/VP AIS and RDI
- ATM Channel Explorer

PDH Mux/Demux **BN4565/93.58**

For testing of legacy PDH/T-carrier systems. Generates structured signals from nx64 Kbps to 140 Mbps.

PDH

Output signal hierarchy 2, 34, 140 Mbps
 Structure depth nx64 Kbps, 2, 8, 34 Mbps
 E1 Sa bit Tx generation and Rx display

T-carrier

Output signal hierarchy 1.5, 45 Mbps
 Structure depth nx64 Kbps, 1.5, 45 Mbps (M13 framing)

Concatenated Mappings **BN4565/93.59**

Enables measurements of contiguous concatenated signals (STM-4c/-16c)

- VC-4-4c (requires optical interfaces STM-4 or higher)
- VC-4-16c (requires optical interface STM-16)
- STS-12c (requires optical interfaces STM-4 or higher and SONET option)
- STS-48c (requires optical interface STM-16 and SONET option)

SONET STS-1/STS-3c/OC-12c(3) Mapping **BN4565/93.62**

Enables the generation and receiving of STS-3/OC-3 and OC-12 signals. Transmitter and receiver specifications as defined. Signal structures and measurements as defined for SDH above.

The following mapping is provided:

- 599040 Kbps via STS-12c SPE
- E4 via STS-3c SPE
- DS3/E3 via STS-1 SPE

Remote GUI/Operation **BN4565/93.60**

Enables the remote operation of the ANT-5 via V.24 or Ethernet from a software emulation of the instrument running on a Windows PC as a remote GUI.

The Remote Operations Client (ROC) supports the following languages, which are user selectable via the main menu:

English, German, French, Italian, Spanish, Portuguese, and Chinese

Remote Control **BN4565/93.61**

Enables the remote control of the ANT-5 over V.24 using an SCPI command set.

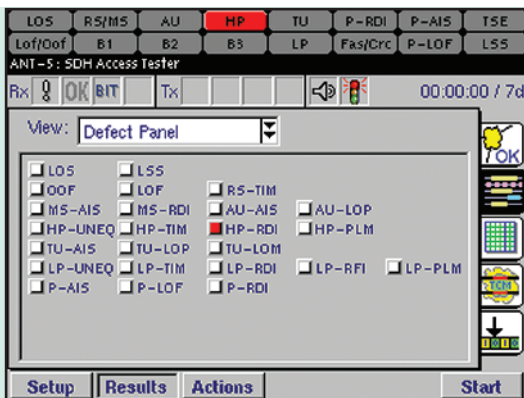

Figure 14: Defect panel view

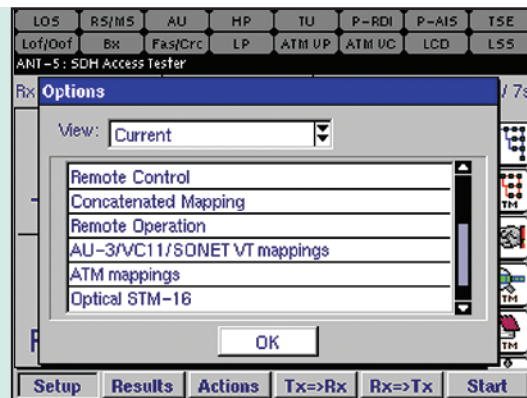

Figure 15: Review current options or install new options

Ordering Information

Description	Part number
ANT-5 PDH/SDH Access Tester – BN4565/50	
Optical options (equipped with FC/PC interface)	
Optics STM-1 1310 SR	BN4565/00.01
Optics STM-1 1310SR/1550LR	BN4565/00.03
Optics STM-1/-4 1310 SR	BN4565/91.13
Optics STM-1/-4 1310SR/1550LR	BN4565/00.14
Optics STM-1/-4 1310LR/1550LR	BN4565/91.15
Optics STM-1/-4/-16 1310LR/1550LR	BN4565/91.16
Options (New Build)	
<i>Only applicable when ordering with a new unit.</i>	
Concatenated Mappings	BN4565/93.59
PDH Mux/Demux	BN4565/93.58
Remote GUI/Remote Operation	BN4565/93.60
Remote Control/SCPI Command List	BN4565/96.61
SONET option (STS-1, STS-3c, OC-12c)	BN4565/93.62
SDH AU-3/SONET VT Mapping	BN4565/93.53
ATM option	BN4565/93.54

ANT-5 STM-1 Package	
ANT-5 PDH/SDH Access Tester	BN4565/50
*CF Card (>16 MB) and Adapter	BN4565/00.42
*Neckstrap	BN4562/00.53
*PPS-2 Power Supply	BN4565/00.57
*Power Cord (Select European, US, Australian, UK)	
*Operating Manual (Select English, German, French, Italian, Spanish, Portuguese, Chinese)	BN4565/98.xx
Optics STM-1 1310SR/1550LR	BN4565/00.03
PDH Mux/Demux	BN4565/93.58
SDH AU-3/SONET VT Mapping	BN4565/93.53
Remote GUI/Remote Operation	BN4565/93.60
Soft Carrying Case	BN4518/00.08
Printer Cable	K1524
Serial to Parallel Printer Cable	K1589
BNC to BNC (2 m)	K169**
RJ-48 (M) to 2xCF	K1597
RJ-48 (M) to RJ-48 (M)/(F)	K1599
FC-PC to FC-PC	K1605**

**Included with the PDH/SDH Access Tester*

***When selecting these cables, please order 2 pieces (one is required for Tx and one is required for Rx)*

Options (Customer Installed)

Only applicable for upgrades of already delivered units.

Please specify the serial number of the instrument when ordering.

Concatenated Mappings	BN4565/95.59
PDH Mux/Demux	BN4565/95.58
Remote GUI/Remote Operation	BN4565/95.60
Remote Control/SCPI Command List	BN4565/96.61
SONET option (STS-1, STS-3c, OC-12c)	BN4565/95.62
SDH AU-3/SONET VT Mapping	BN4565/95.53
ATM option	BN4565/95.54

Accessories

*CF Card (>16 MB) and Adapter	BN4565/00.42
*Neckstrap	BN4562/00.53
*PPS-2 Power Supply	BN4565/00.57
*Power Cord (Select European, US, Australian, UK)	
*Operating Manual (Select English, German, French, Italian, Spanish, Portuguese, Chinese)	BN4565/98.xx

**Included with the PDH/SDH Access Tester*

Transportation Cases

Hard Carrying Case	BN4565/00.76
Soft Carrying Case	BN4518/00.08

ANT-5 STM-1/-4 Package

ANT-5 PDH/SDH Access Tester	BN4565/50
*CF Card (>16 MB) and Adapter	BN4565/00.42
*Neckstrap	BN4562/00.53
*PPS-2 Power Supply	BN4565/00.57
*Power Cord (Select European, US, Australian, UK)	
*Operating Manual (Select English, German, French, Italian, Spanish, Portuguese, Chinese)	BN4565/98.xx
Optics STM-1/-4 1310SR/1550LR	BN4565/00.14
Concatenated Mappings	BN4565/95.59
PDH Mux/Demux	BN4565/93.58
SDH AU-3/SONET VT Mapping	BN4565/93.53
Remote GUI/Remote Operation	BN4565/93.60
Soft Carrying Case	BN4518/00.08
Printer Cable	K1524
Serial to Parallel Printer Cable	K1589
BNC to BNC (2 m)	K169**
RJ-48 (M) to 2xCF	K1597
RJ-48 (M) to RJ-48 (M)/(F)	K1599
FC-PC to FC-PC	K1605**

*Included with the PDH/SDH Access Tester

**When selecting these cables, please order 2 pieces (one is required for Tx and one is required for Rx)

Peripheral cables

Printer Cable	K1524
Modem Cable	K1550
Serial to Parallel Printer Cable	K1589

Optical Cables (Singlemode, 2 meters)

FC-PC to FC-PC	K1605**
FC-PC to SC/PC	K1606**
DIN 47256 to FC-PC	K1607**
FC-PC to E2000	K1608**
FC-PC to E2000APC	K1609**
FC-PC to ST-PC	K1610**
FC-PC to Radiall VFO	K1611**
FC-PC to FC-APC	K1612**
FC-APC to FC-APC	K1613**

Electrical Cable

BNC to BNC (2 m)	K169**
RJ-48 (M) to 2xCF	K1597
RJ-48 (M) to RJ-48	K1598
RJ-48 (M) to RJ-48 (M)/(F)	K1599

**When selecting these cables, please order 2 pieces (one is required for Tx and one is required for Rx)

ANT-5 STM-1/-4/-16 Package

ANT-5 PDH/SDH Access Tester	BN4565/50
*CF Card (>16 MB) and Adapter	BN4565/00.42
*Neckstrap	BN4562/00.53
*PPS-2 Power Supply	BN4565/00.57
*Power Cord (Select European, US, Australian, UK)	
*Operating Manual (Select English, German, French, Italian, Spanish, Portuguese, Chinese)	BN4565/98.xx
Optics STM-1/-4/-16 1310LR/1550LR	BN4565/91.16
Concatenated Mappings	BN4565/95.59
PDH Mux/Demux	BN4565/93.58
SDH AU-3/SONET VT Mapping	BN4565/93.53
Remote GUI/Remote Operation	BN4565/93.60
Soft Carrying Case	BN4518/00.08
Printer Cable	K1524
Serial to Parallel Printer Cable	K1589
BNC to BNC (2 m)	K169**
RJ-48 (M) to 2xCF	K1597
RJ-48 (M) to RJ-48 (M)/(F)	K1599
FC-PC to FC-PC	K1605**

*Included with the PDH/SDH Access Tester

**When selecting these cables, please order 2 pieces (one is required for Tx and one is required for Rx)

Global Service Solutions from Acterna provide the expertise and resources to enhance your communications test and management capabilities. From basic instrument support for your field technicians, to the management of complex, company-wide initiatives, Acterna's service professionals are committed to helping you maximize your performance. Whatever your needs — product support, system management, education solutions, consulting services, or refurbished equipment — Acterna offers the programs that will give you the competitive edge. To learn more about how Acterna's Global Service Solutions can help your business be more successful, visit the "Services" section at www.acterna.com.

Acterna is the world's largest provider of communications test solutions for telecommunications and cable network operators. A trusted communications test partner for more than eight decades, Acterna offers an unmatched portfolio of award-winning instruments, systems, software and services that help its customers reduce network costs while improving performance and reliability. Headquartered in Germantown, Maryland, USA — with European and Asia-Pacific operations based in Eningen, Germany and Hong Kong — Acterna serves nearly every major communications service provider and equipment manufacturer around the world through a skilled sales and support organization in 31 countries.

Worldwide Headquarters

One Milestone Center Court
Germantown, Maryland
20876-7100
USA

Acterna is present in more than 80 countries. To find your local sales office go to: www.acterna.com

Regional Sales Headquarters

North America
One Milestone Center Court
Germantown, Maryland
20876-7100
USA
Toll Free: 1 866 ACTERNA
Toll Free: 1 866 228 3762
Tel: +1 301 353 1560x2850
Fax: +1 301 353 9216

Latin America
Acterna do Brasil Ltda.
Av. Eng. Luis Carlos Berrini
936 9th Floor
04571-000 São Paulo
SP-Brazil
Tel: +55 11 5503 3800
Fax: +55 11 5505 1598

Asia Pacific
Acterna Hong Kong Ltd.
Room 902, 9th Floor
Bank of East Asia
Harbour View Centre
56 Gloucester Road
Wanchai, Hong Kong
Tel: +852 2892 0990
Fax: +852 2892 0770

Western Europe
Acterna Germany GmbH
Mühleweg 5
Germany
Tel: +49 7121 86 2222
Fax: +49 7121 86 1222

Eastern Europe, Middle East & Africa
Acterna Austria GmbH
Aredstrasse 16-18
A-2544 Leobersdorf
Tel: +43 2256 65610
Fax: +43 2256 65610-22

Acterna Moscow
Prospect Mira 26,
stroenie 5
RF-129090 Moscow
Tel: +7 095 937 88 04
Fax: +7 095 775 26 05

© Copyright 2004
Acterna, LLC.
All rights reserved.

Acterna, Communications Test and Management Solutions, and its logo are trademarks of Acterna, LLC. All other trademarks and registered trademarks are the property of their respective owners. Major Acterna operations sites are ISO 9001 registered.

Note: Specifications, terms and conditions are subject to change without notice.

